

Buck® MC Valve



Buck®

Modular High Containment Interface

GEA Pharma Systems supplies advanced technologies for the processing of Active Pharmaceutical Ingredients (API) for the production of oral and parenteral dosage forms.

GEA Pharma Systems strives for *Price/Performance Leadership* providing its customers with highly cost-effective, integrated systems for the pharmaceutical industry. GEA Pharma Systems is dedicated to innovation and thereby providing durable quality through its well-established brands: **Aeromatic-Fielder™** and **Collette™** - batch and continuous granulation, drying, pelletizing and coating; **Buck®** - contained materials handling; **Courtoy™** - tablet compression; and **Lyophil™** - pharmaceutical freeze drying.

GEA Pharma Systems' activities include partnering with customers to develop new products and enhance clinical effectiveness; the supply of R&D-scale and stand-alone production equipment; and the installation of complete integrated production lines.

Modular High-Containment Interface

For over 10 years, Buck® has supplied dust- and contamination- free containment interfaces for the safe transfer of powders, particulates and tablets in the pharmaceutical industry.

These interfaces ensure the protection of both people and products when charging and discharging high-potent APIs.

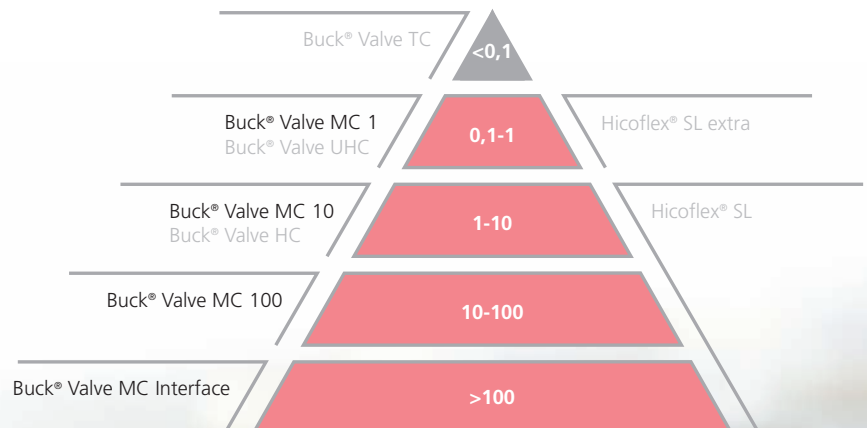

Containment Levels:
Short Term Exposure ST TWA [mcg/m³]



Buck® MC Valve for rigid transport containers

The Buck® MC Valve concept unifies all the current requirements in high containment equipment: full GMP design, no need for lubrication, no need for vacuum, robust centering, free orientated docking, quick release without any tools as standard.

But the most innovative step is the idea of using only passive valves driven by a modular actuator unit.

Process description

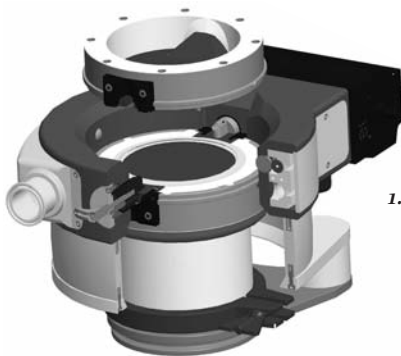

1. undocked,
unlocked & closed

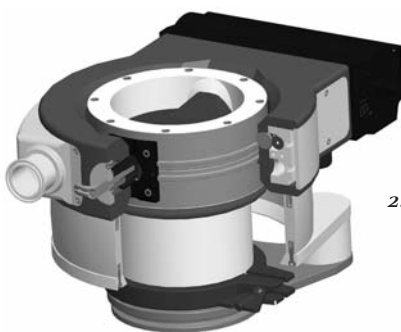

2. docked, locked
& closed

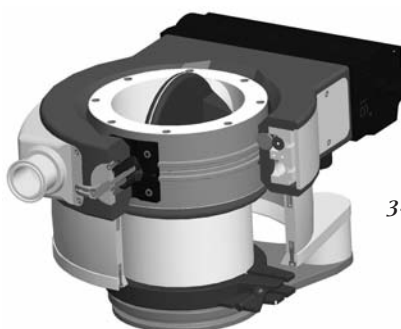

3. docked, locked
& opened



Benefits

Cost Saving

- cost efficient, tailor made solution
- low maintenance

Safety

- high operator and product protection

Flexibility

- modular containment concept
- direct IBC to IBC transfer
- very few tubing and cabling (no vacuum required, integrated locking)
- quick release as standard

Modular High-Containment Interface



Typical applications

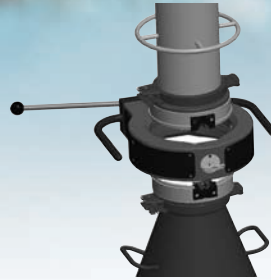

Manually handled and operated MC Valve

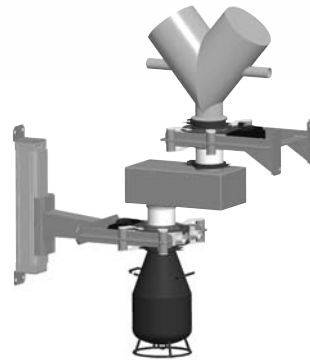

Contained charge/discharge of process units

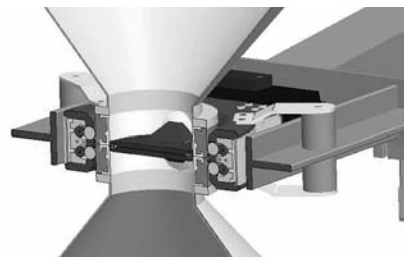

Contained IBC to IBC transfer (MC passive to passive)



MC Valve in use as standard butterfly valve

Accessories

- Vibroflow
- Wash adaptors
- Transition pieces

Specifications

Suitability powders, granules, pellets, tablets

- Features**
- 100% FDA conformity
 - anti-static seal material available
 - product contacting materials: AISI 316L
 - specialities available on demand

Options All product contacting parts are available in hastelloy or coated version



Central Know-How on a Global Scale

Based on a strong commitment to research and development, pharmaceutical technology centres in Belgium, Denmark, Switzerland, the UK, Singapore, and USA provide global technical support and know-how to the pharmaceutical industry. These centres

of excellence give customers access to a range of test facilities and expert teams with technical and process know-how. Our teams work closely with our customers to optimise processes and evaluate their products, enabling them to achieve their process and production goals.



Contracting Profitable Experience

A world leader in supplying pharmaceutical equipment, GEA Pharma Systems offers manufacturers all over the world the opportunity to enter into a profitable partnership for development and contract. GPS combine advanced in-house technology with a thorough

understanding of the pharmaceutical industry to help customers maximize their development results.



© GEA Pharma Systems 2009 Specifications subject to change without notice. All trademarks recognized

T	+ 44 (0) 845 5053530	S3 Process Limited, Stowegate House, 37 Lombard Street, Lichfield, WS13 6DP, UK s3process.co.uk	
E	info@s3process.co.uk		